

使用说明书

No.14892



说明

2

14911 14912 14913

20ml

3. _____

4.

5.

- : _____
- : _____ (20ml)
- : _____

6.

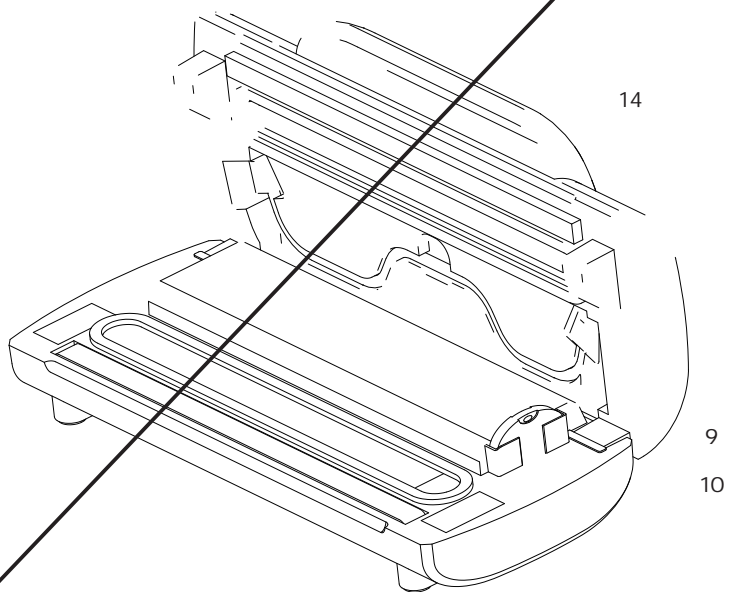

3. _____

7.

8.

9.

10.

11.

12.

13.

14.

4

- 1.
- 2.
- 3.
- 4.
- 5.
- 6.
- 7.

(1)

2

3

4

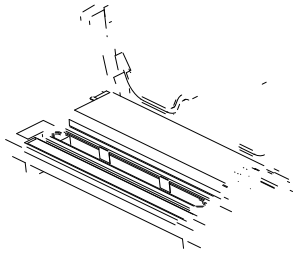

1

2

3

4

5.

1.

2.

3.

4.

5.

6.

1

7.

60

8.

9.

10.

6.

1.

2.

3.

4.

5.

•

•

7.

1.

2.

3.

1.

2.

3.

4.

1.

2.

3.

4.

1.

2.

7.

3.

8.

| | |
|--|---------------------|
| | AC 220V /50Hz |
| | 120W |
| | 20S |
| | 30 S 22cm× 30cm |
| | - 70 kPa |
| | 300 mm |
| | 400mm× 183mm× 104mm |
| | 2kg |

9.

| | Pb | Hg | Cd | Cr | PBB | PBDE |
|--|----|----|----|----|-----|------|
| | ○ | ○ | ○ | × | ○ | ○ |
| | ○ | ○ | ○ | ○ | ○ | ○ |
| | ○ | ○ | ○ | ○ | ○ | ○ |
| | ○ | ○ | ○ | ○ | ○ | ○ |
| | ○ | ○ | ○ | × | ○ | ○ |
| | ○ | ○ | ○ | × | ○ | ○ |
| | ○ | ○ | ○ | × | ○ | ○ |
| | ○ | ○ | ○ | ○ | ○ | ○ |
| | ○ | ○ | ○ | × | ○ | ○ |
| | ○ | ○ | ○ | ○ | ○ | ○ |

○ SJ/T11363- 2006

×

SJ/T11363- 2006 